

6055C-nGHD OPTIONS & APPLICATIONS

The 6055C-nGHD is a multi-channel HD video insertion system that ITS has been shipping since 2011. The system is designed to accept any SMPTE 259M, 292M and 424M (3G) compliant HD-SDI video stream, create or read KLV packs (first three on line 9), overlay text in each frame and retransmit HD-SDI (reclocked and buffered) for up to 100 meters. The product samples GPS or IRIG B time to within 2 μ sec of each EAV (equivalent to analog vertical sync) event and can overlay the captured time value at user programmable resolutions of 1 second to 1 μ sec in decade increments. The time collected may also be recorded in a KLV pack that is a MISB 605.3 compliant Microsecond Timestamp. Each channel independently auto-detects and decodes the imaging format permitting most SDI 720p, 1080i and 3G 1080/p at 24/1.001, 24, 25, 30/1.001, 30, 50, 60/1.001 or 60 fps to be connected without operator intervention. The time message and up to 3,920 ASCII characters may be inserted into the active video image, with the color and location selected by the user. The 6055C-nGHD family may overlay a fixed boresite crosshair (3 sizes) or a movable crosshair (3 sizes). The movable crosshair is positionable in 1-pixel increments. The time reference is derived from either the internal GPS receiver or an external IRIG B time code. All functions and controls are available from the supplied keyboard, or remotely via the Ethernet or RS-232 ports.

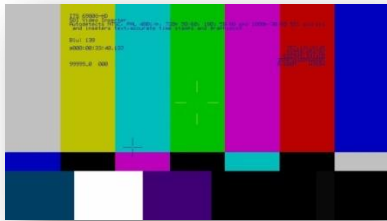

The time message and up to 3,920 ASCII characters may be inserted into the active video image, with the color and location selected by the user. The 6055C-nGHD family may overlay a fixed boresite crosshair (3 sizes) or a movable crosshair (3 sizes). The movable crosshair is positionable in 1-pixel increments. The time reference is derived from either the internal GPS receiver or an external IRIG B time code. All functions and controls are available from the supplied keyboard, or remotely via the Ethernet or RS-232 ports.

6055C-nGHD as a time standard and HD recording Support System

Selecting all of the options available and some new ones to be released in October 2013, the 6055C-nGHD can be used to not only insert text and crosshairs on video, but can synchronize an array of HD-SDI video cameras and provide live video monitoring channels while recording clean HD-SDI video among other possibilities. In the block diagram below, an example of a 2-channel 6055C is shown configured as a single channel video recording support system (see A Scalable Solution for 4, 6, and 8 channel options).

This single 2U chassis controlled over an Ethernet interface can insert text, crosshairs, time stamp and even

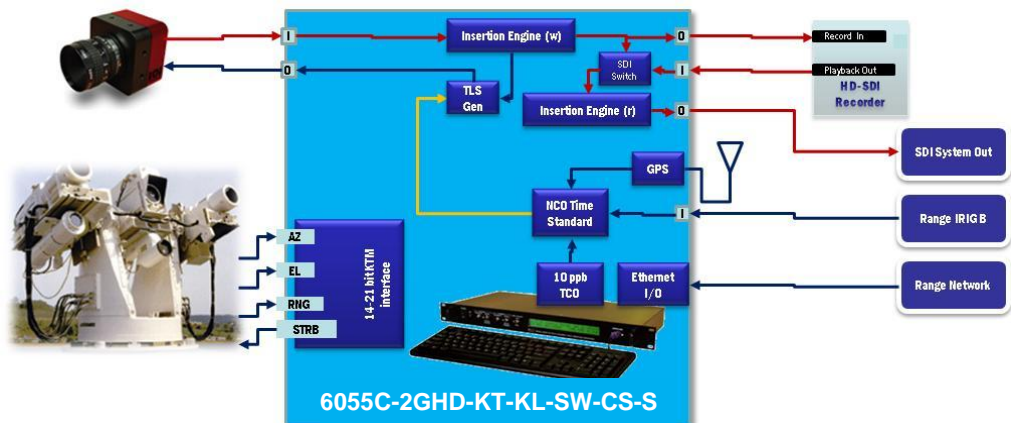

azimuth (AZ), elevation (EL) and sensor range data in real time on the output SDI video channel.

It can also synchronize the camera connected to it (tri-level camera sync option) to be in phase lock with the 1PPS GPS, or an external IRIG B time reference. An operator can adjust this sync relative to the GPS/IRIG time mark so that the picture taking instance of this camera can be aligned with other cameras even of different imaging technologies (see Calibration of Picture Taking & Data Collection; CS Option, below for details).

Another new feature is SDI video switching. A benefit of the availability of KLV metadata defined by the SMPTE standard is that one can record video without overlay. Data collected can be placed in metadata out of sight. The data itself can be time-relevant, image-relevant or both. In any case, the data is in permanent lockstep with the images making post mission correlation direct and straightforward. If an SDI recorder is used that can preserve VANC metadata in the record and playback modes correctly, then one can record “clean” video. Using the SDI switch (see SDI Switch; SW Option available in October 2013) one will be able to monitor the live video and overlay what is being recorded in the VANC metadata space and overlay crosshairs and other contemporaneous data while sending clean video to the recorder. At playback, once more the “playback” channel can be set to decode the VANC metadata and overlay what information is needed for analysis after the fact.

In many test scenarios, GPS and even IRIG time may not be available or reliable during the mission. A current option of the 6055C-nGHD is the integration of Stratum 3 oven controlled oscillator (see Accurate Time without GPS/IRIG during a test; S Option for details). Our design disciplines this oscillator relative to the 1 PPS interval while locked to either the internal GPS time reference (1 PPS) or external IRIG B time reference. With only 30 minutes locked to a reference for disciplining, the 6055C-nGHD internal time standard will drift with respect to the last synchronized time less than 4 microseconds/hour; *<32μsec drift in an 8 our unlocked interval!*

Lastly, many years ago ITS developed a parallel interface that connects to the Kineto Tracking Mount (KTM) Interface. This currently available KT option collects azimuth, elevation and range sensor data every 16μsec. When selected, the 6055C-nGHD may automatically insert into video or optionally write to the current KLV VANC metadata pack the collected values at each equivalent of video vertical sync.

Other image-relevant data may be collected from the Ethernet interface and included in the VANC metadata.

ITS has proposed an Instrumentation KLV metadata pack that has the capacity to save a wide range of instrumentation data and make it available for later data analysis and real-time overlay (see Up to 2 KLV data packets; KL Option).

For details about VANC metadata and KLV packs, please refer to the ITS White Paper entitled **METADATA: WHERE-WHAT-WHO.**

Calibration of Picture Taking & Data Collection; CS Option

A new option available in October of 2013 with the 6055C HD product line is *Camera Sync (CS)*. The CS function generates a SMPTE compliant tri-level sync pulse stream that is phase synchronized to a time reference (e.g. GPS or IRIG). The CS function also adds the capability to delay the key point (O_H , see SMPTE diagram, below). The delay may be from 0-32 milliseconds (about a 30FPS frame time) in one-microsecond steps. The delay may be set independently for each channel of the system. This feature enables a user to calibrate picture taking of each camera such that they are not only synchronized in time, but the frames captured by each is aligned.

Since each video channel may be adjusted independently, picture-taking alignment can be achieved with cameras of different technologies (e.g. CCD, CMOS or IR).

Since the 6055C is generating the input synchronization, another command is available to instruct the 6055C to collect time on the 0_H point going to the camera. With the KTM option, 0_H is also when the 6055C collects the mount data. This integrated capability more tightly aligns the imagery with the corresponding data.

If the time from input 0_H to completion of image-integration for the specific camera is known, an offset may be applied to the timestamp such that the time recorded with the video is adjusted to match the actual image capture time. The timestamp offset has a resolution of 1 microsecond and a range of ± 16 milliseconds.

The tri-level pulse stream to be applied to the camera is different from format to format. The format may be set by a command (image resolution such as 1080 and frame rate), or the CS function may be set to auto-detect. In this mode, the camera must always generate HD-SDI video. In this mode, the 6055C will first decode the incoming HD-SDI video stream and automatically determine the resolution and frame rate. These values will be the settings of the CS function. Therefore, any camera within the operating range of the 6055C system will automatically be synchronized to the available time reference. Sync offset is independently set by the user and is not affected in CS auto-sync mode.

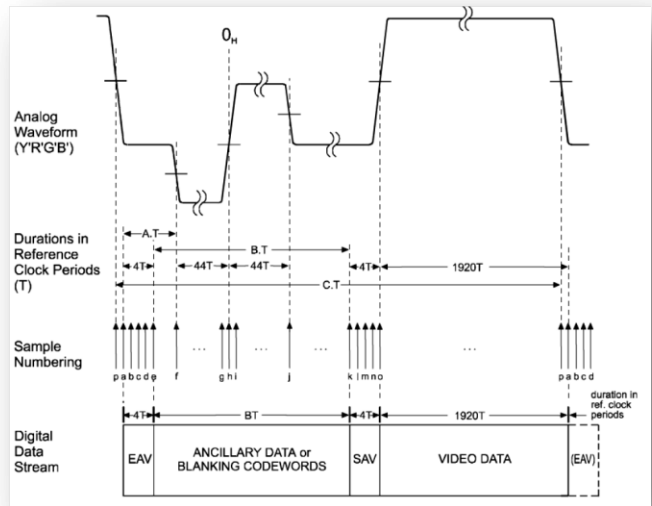

Accurate Time without GPS/IRIG during a test; S Option

The 6055C-nGHD product offers the ability to synchronize to an external IRIG B time reference, the internal GPS or to an optional internal and disciplined Stratum 3 oven controlled oscillator. After a 10-minute warm up time and with at least 20 minutes of synchronization lock to GPS or IRIG B, the 6055C will maintain a time drift of less than 3 μ seconds/hour. The actual time will be within 100 nanoseconds at the start of lost lock from GPS or within 6 μ seconds at the start of lost lock from IRIG B. In either case, time will be accurate with less than a 40 μ sec error after a full day of operation without the benefit of an available primary time reference.

The disciplined Stratum 3 clock is the time control basis for the camera sync, time stamping and other time related functions. Therefore, the time relationship between picture taking, time stamping and mount data collection is unaffected by losing time reference lock.

SDI Switch; SW Option

Internal to the 6055C design is a two-channel HD-SDI Video Insertion Engine. Each engine can write and read KLV data and when desired overlay it onto the video frames in either mode. An available option (SW, see the image to the right) for the 6055C-nGHD is to include a SDI switch that permits an operator to select the input of one of the channels to be

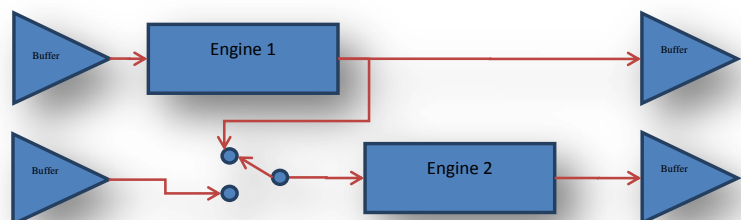

the output of the other or an external input.

The buffers are SDI buffers (input) – Drivers (output) and are connections from and to the outside world. When the switch is connected to the input buffer, Engine 2 behaves as a normal single channel HD-SDI insertion engine. When the switch is connected to the output of Engine 1, Engine 2 can serve as a monitor for the video being sent to the Engine 1 output. This enables an operator to write only KLV time stamps and instrumentation data with Engine 1 for recording and set Engine 2 to read and overlay desired KLV data in the video stream of Engine 2. The result is a monitoring channel that can have video overlay of live mission information for situational awareness, while the recording channel (output of Engine 1) is clean video.

This option can be selected for channel pairs which makes this a scalable solution. That is, a single channel system intended to provide clean video recording and live situational awareness and monitoring can be accomplished with a 6055C-2GHD-SW, a two-channel system with a 6055C-4GHD-SW, a three-channel system with a 6055C-6GHD-SW and a four-channel system with a 6055C-8GHD-SW.

Up to 2 KLV data packets; KL Option

The KL option is a complete end-to-end system enabling you to fully utilize the powerful SMPTE KLV pack architecture for data collection and measurement purposes.

The ITS inserter hardware combined with the KLV Software Toolkit deliver the ability to

- **Create** a Key
- **Design** the value content
- **Monitor** incoming value data
- **Transport** value data embedded in the HD-SDI stream
- **Extract** value data from the HD-SDI stream
- **Display** all or selected value data (embed in the video)
- **Test** your key/value content design
- **Read from file** the data of the saved file record-by-record

With the KL Option, a user may specify one or two additional type 2 (VANC space) KLV packs to be written with the HD Inserter. These packs are located immediately after the Microsecond Timestamp KLV pack on line 9 of every frame. The length (L) specifies how many bytes of value (V) there are. The key (K) is a look up reference that will identify the content and format of the V.

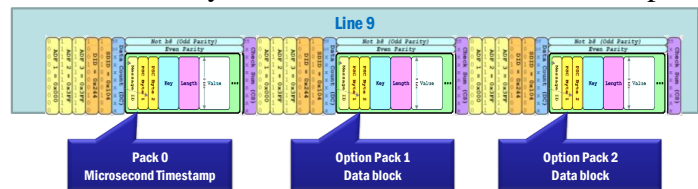

Both OptionPack 1, and OptionPack 2 are SMPTE 291M compliant ensuring compatibility with all commercial HD-SDI recording, display and workflow equipment.

The value (V) of each pack is comprised of up to 235 bytes of user definable data which may be a mix of binary, integer and floating point values and ASCII characters. With careful synchronization, the data enclosed in each KLV pack may be tightly related to the image frame it is written to. In the limit, 470 bytes of data can carry up to 150 separate 24 bit integer data items or up to 58 double precision floating point data items at a data rate of 28.2K bytes/second with a 720p/60, 1080p/60 SDI video stream.

When the KTM option is installed in the 6055C, it can be instructed to collect the AZ, EL and Range data available from the KTM interface and automatically embed it in the Instrumentation Packet. If

sent to the 6055C (or available from an optional interface) in a timely fashion, every frame will carry with it an instrumentation packet with frame specific time coherent data.

The resultant HD-SDI stream will have the video, all of the original HANC data (payload, audio, SMPTE time, etc.) and have two VANC packets inserted by the 6055C, the Metadata Timestamp packet and the proposed Instrumentation packet.

The 6055C or a 6980G-HD (with the KLV option) may be used to receive HD-SDI video bit streams to collect the VANC packets and display data on the image at the locations (rows and columns) desired. Additionally, either of these systems may also be instructed to present the packets to the device Ethernet interface on a frame by frame basis.

If recorded, none of this data must be placed in the active image area of the frame. Clean video may be recorded. The recorder used must preserve the VANC space packets and reconstruct them correctly and in the correct frame to accomplish overlay.

A KLV Software Toolkit is included at no additional charge. The toolkit is comprised of

1. An MS Excel workbook, ITS **KeyTemplate**[®], that provides a means to easily create an encoder design that can be used to prepare V(alue) data blocks. Data blocks can each be composed of up to 64 independent fields of data.
2. A GUI, **Configuration Utility**, that can import a CSV output of the KeyTemplate[®] and formulate the command(s) necessary for the inserter to decode and display the data while writing (monitor incoming data) or reading (extracting) from the HD-SDI incoming stream.
3. A GUI, **Key Test**, is designed to provide a means to input data to the KLV design. The Key Test GUI can be linked to any key that has been imported by the Configuration Utility.
4. A GUI, **Key Read**, that can be linked to any user defined key built with the KL Software Toolkit.

For complete details, please refer to the KLV Tool Set Application Note on our website, www.ITSamerica.com.

A Scalable Solution

The 6055C-nGHD with these options can support 1,2,3 and 4 channel HD-SDI video systems. These units are packaged in 2U and 3U rack mount chassis. All channels, no matter how many, are controlled via a single Ethernet interface. Each channel is comprised of two HD-SDI engines internally where

1. the “record” engine accepts the output of an HD-SDI camera, the record engine outputs SDI intended as the input channel of an SDI recorder
2. the playback channel can be switched to accept the output of the “record” record channel, or the output of the HD-SDI recorder playback channel. The output of the “playback” engine may be sent to an SDI monitor, an SDI-to-H.264 or SDI-JPEG2000 encoder for broadcast over a network or other video viewing service.

Exemplifying scalability, the block diagram below shows an 8-channel 6055C configured as a 4-channel Recording Support System.

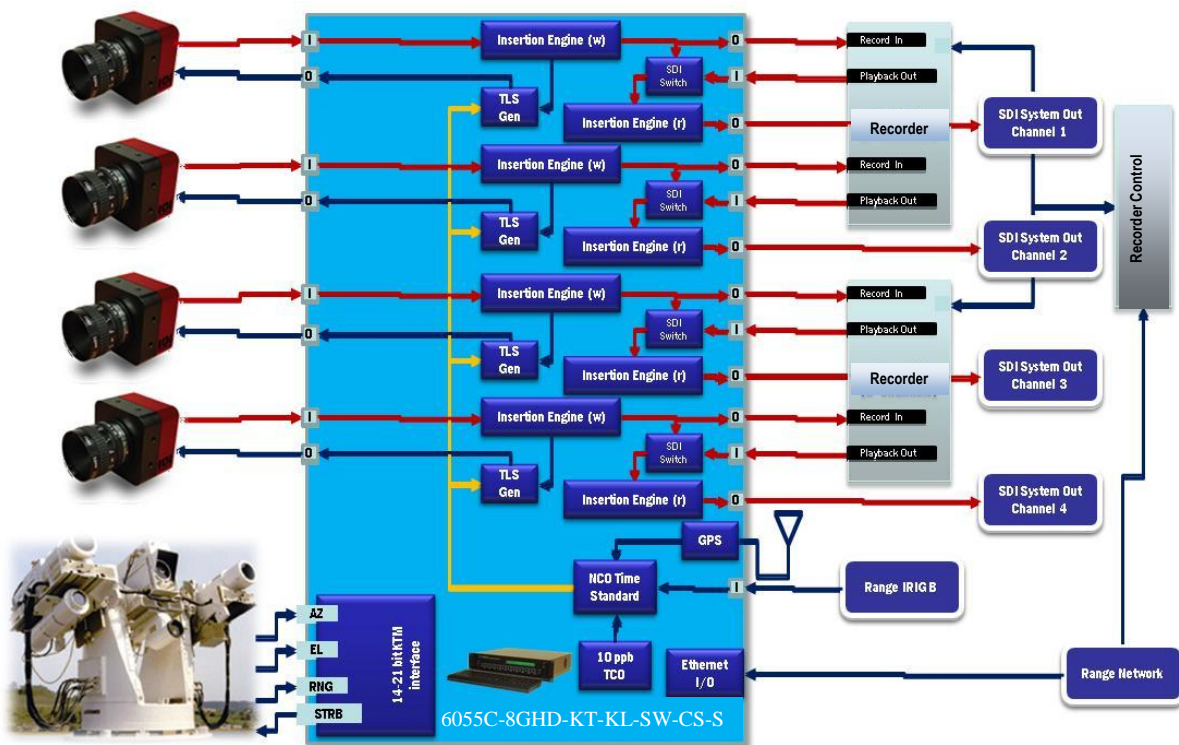

For more information contact

Instrumentation Technology Systems
(818) 886-2034 • (818) 886-7573 (fax)
sales@ITSamerica.com
www.ITSamerica.com